

PERIPHERALS

TOOL SET UP STATION

Work table
6S DESK



6SD

➔ P. 220

Tool washing machine
CLEAN BOX



CBX

➔ P. 221

Cutting tool cover
TOOL CAP TCC type

TCC



➔ P. 222

Cutter protection box
ENDMILL HOUSE

EMO

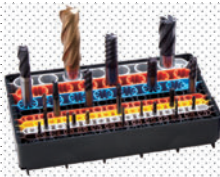

➔ P. 223

**TOOL HOLDER
STORING CABINET**

HBX



➔ P. 224

Tool clamping fixture
**TOOL SET UP
STAND**

**Petit Ball
MY CUBE
HF SERIES**



➔ P. 225

Cleaning Tool
for a spindle taper hole
STAR DUST

CLT



➔ P. 226

For machine spindle
maintenance
**TEST BAR
CHECKMATE**

**CMA
CMB**

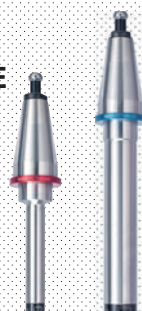

➔ P. 227

Set up the original point
on the Z axis / measuring tool
for reference position
Goo CHECKER

ZPM



➔ P. 228

The teaching DVD
with practical maintenance tools
MAINTENANCE VIDEO

MTN



➔ P. 229

TOOL SET UP STATION 6S DESK

Work table

Ensures safe tool settings! Improves the work environment in the factory!

- ▷ Helps in the rapid implementation of the five S's in your factory.
- ▷ Compact and space saving.
- ▷ Do-it-yourself style allows you to do assembly.



White board and Punched board

Useful as a bulletin board or message board, and for attaching drawings. Freely mounting position on the left or right side.

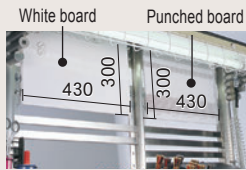

Tool insert stand (option)

Insert and store frequently used hand tools, stationary, etc.



Shelf board

Shelf is deep enough for a laptop computer, and the shelf can be attached at whatever height you desire.

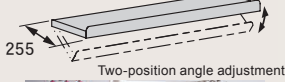

Hook base panel

Arbitrary attachment and recombination. Effective utilization of a rear space.



Usage example of backside application

Trash cans are not provided.

Dust Shooter (option)

Easy trash separation. Comes with two kinds of sign seals.



Upper lighting

Safety light cover.

Lower lighting

Brightly lit, safe work space.



Air gun

Can be mounted on either the right or left.

Safety stopper

Prevents dropping of cutting tools and tool holders.



Lighting switch and socket

Upper lighting (32W) and under shelf lighting (20W) (max.capacity 1500W)



Tabletop

The tool setup stand (sold separately) can be installed anywhere using the tabletop holes. No need to put your own holes in the tabletop.



Container box

The see-through box allows easy storage and organizing.



Side Table (option)

Side Table comes with:
Container box (CN-103) 1pc.
Container box (CN-150) 2pcs.
Container box lid (CN-FT) 3pcs.

Tool Set Up Stand (option)

▷ P. 225



MY CUBE

Petit Ball

※This image includes the options. Tool is not included

CODE

6SD-01

For details, please contact MST and ask for a catalog.



Dimensions

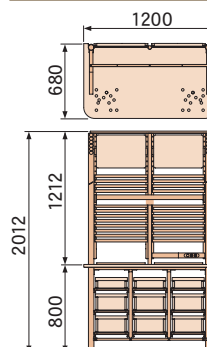

132 kg

Uniformity with stand load 100 kg

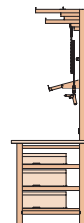

Std. Access.

CODE	Description	Q'ty	Description	Q'ty
6SD-FBP	Hook base panel	12pcs.	Shelf board	1pc.
-FS	Short hook	3pcs.	Upper lighting / Lower lighting	1ea.
-FL	Long hook	2pcs.	※Select 50Hz or 60Hz	
-UFS	U-type short hook	3pcs.	Power code set	1set
-UFL	U-type slong hook	1pc.	(Socket / Lighting / switch / Powercode)	
-FSP	Hook fot spanner	1pc.	White board.	
-FDR	Hook fot driver	1pc.	Marker pen for whiteboard.	
CN -103	Container box	3pcs.	Whiteboard eraser.	1set
-150		6pcs.	Magnet pocket.	
6SD-AIR	Air gun set	1set	Punched board.	
			Name seal set.	
			Magnets(3pcs.).	
			Memo book.	

Caution

- Assembly by buyer.
- Customers pay the shipping cost.
- 100V electric power supply (transformer is required)

TOOL SET UP STATION CLEAN BOX

Tool washing machine

Wash the tooling holders, collets, nuts, cutting tools, and small work-pieces thoroughly to maintain their accuracy!

- ▷ Wash tool holders, cutting tools and jig fixtures.
- ▷ No plumbing required.
- ▷ Safe cleaning system using water.
- ▷ Built-in water heater improves washing capability.

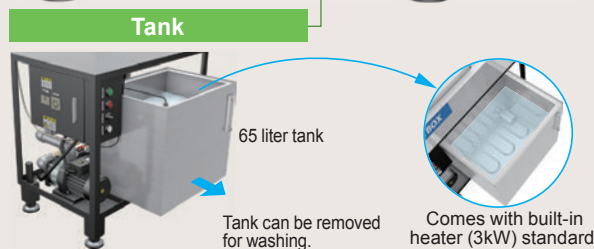
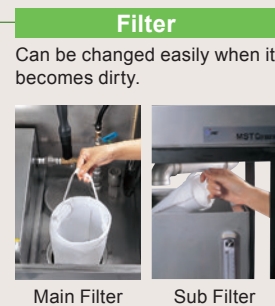
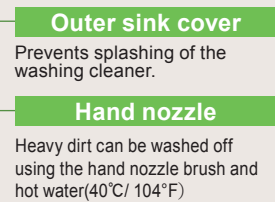
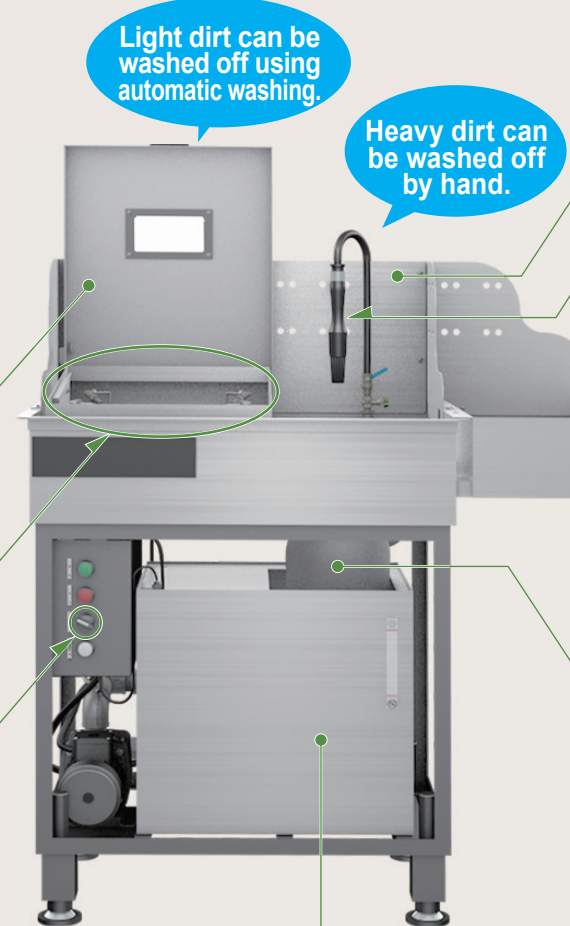
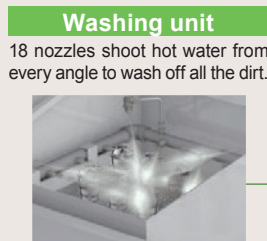

The sink, washing unit and tank are made of stainless steel, resulting in easy maintenance and less staining.

CODE
CBX-01

Dimensions

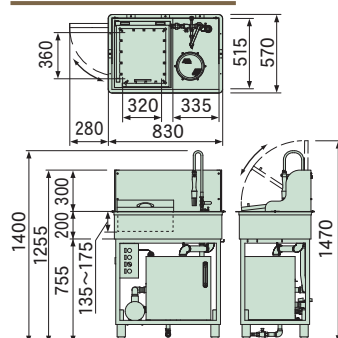

Specifications

Material	SUS304(Sink, Tank, Cleaning unit) SS400 (Base frame)
Tank	Approx. 65L(Level gauge with thermometer is standard accessory)
Pump	0.3~0.51kw (50/60Hz) (Produced by Grundfos)
Heater	3kw (with temperature control)
Weight	Approx. 100kg (165kg, including cleaning fluid)
Voltage	3-phase 200V (Rated 15A)

Std. Access.

CODE	Description	Q'ty
CBX-HNZ	Hand nozzle	1pc.
-MFIL	Main filter	2pcs.
-SFIL	Sub-filter	2pcs.
-TRP	Drain trap	1pc.
-GSTP	Rubber drain plug	1pc.
-WBSK	Washing basket	1pc.
-WTBL	Washing table	1pc.
	Sink outer cover	1set.
	Hook	2pcs.
	Bamboo brush	1pc.
	Primary power code (plug attached 15m)	1pc.

Caution

- Be sure to use water-soluble cleaning fluid.
- Customers pay the shipping cost.
- 200V electric power supply (transformer is required)

See-through tool cover. You can take care of tools safety and simply.



The tool is visible!

Prevents chipping and damage to cutting tools

The cutting tool cover protects the user from injury at the time of work while protecting breakage of the cutting edge. Minimize grinding costs for reconditioning and lead to reduced operating costs.

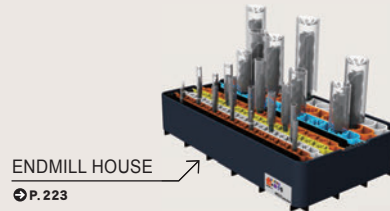

Not slip off



CODE	φD	h ₁	H	Q'ty
TCD03-50	3	—	25	50
TCD04-50	4	—	32	50
TCC0607- 50	5.4~ 6.7	35	40	50
-100				100
-500				500
TCC0709- 50	6.8~ 8.9	35	40	50
-100				100
-500				500
TCC0911- 50	8.9~10.9	65	70	50
-100				100
-500				500
TCC1113- 50	10.9~13.4	65	70	50
-100				100
-500				500
TCC1418- 25	13.8~17.8	100	110	25
- 50				50
-250				250
TCC1822- 25	17.8~22.4	100	110	25
- 50				50
-250				250
TCC2228- 25	22.3~28	135	150	25
- 50				50
-250				250
TCC2836- 10	28 ~36	130	150	10
- 20				20
- 50				50
-200				200
TCC3646- 10	36.2~47	165	190	10
- 20				20
- 50				50
-200				200
TCC4760- 10	46 ~60	160	190	10
- 20				20
- 50				50
-200				200

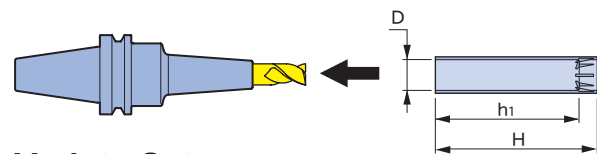

Variety Set

Each size comes in a set of two.

CODE	Q'ty
TCC-F	2 pieces per cutting tool over size for TCC0607 to 4760 (total of 20 pieces per set)

Usage

- 1 Hold the mouth of the tool cap vertically, and then press it so that its oval shape becomes round.
- 2 Once the mouth of the tool cap becomes round, push it into the cutting tool or tool holder.

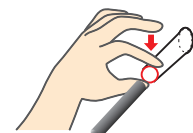
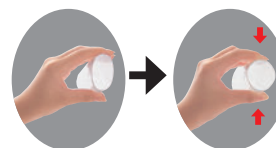

TCA type— Attaches to the tip of a tool holder.

TCB type— Attaches directly to the tip of the cutting tool.



General catalog for further reference...

Feature
Shrink-fit Heater
MONO 3° MONO CURVE
MONO Series
2PIECE type
UNO
HYPER version
STRAIGHT arbor
OTHERS
PERIPHERALS
Technical Information

Are you having trouble storing your cutting tools ?



Cutting tool expenses increase due to cutting edge chipping.

The required cutting tool cannot be found easily.

Save cutting tool expenses and time with the optimum working environment.

- ▷ Cutting tool life is extended because the cutting edge is not dulled from striking other cutters.
- ▷ You can find the required cutting tool immediately.

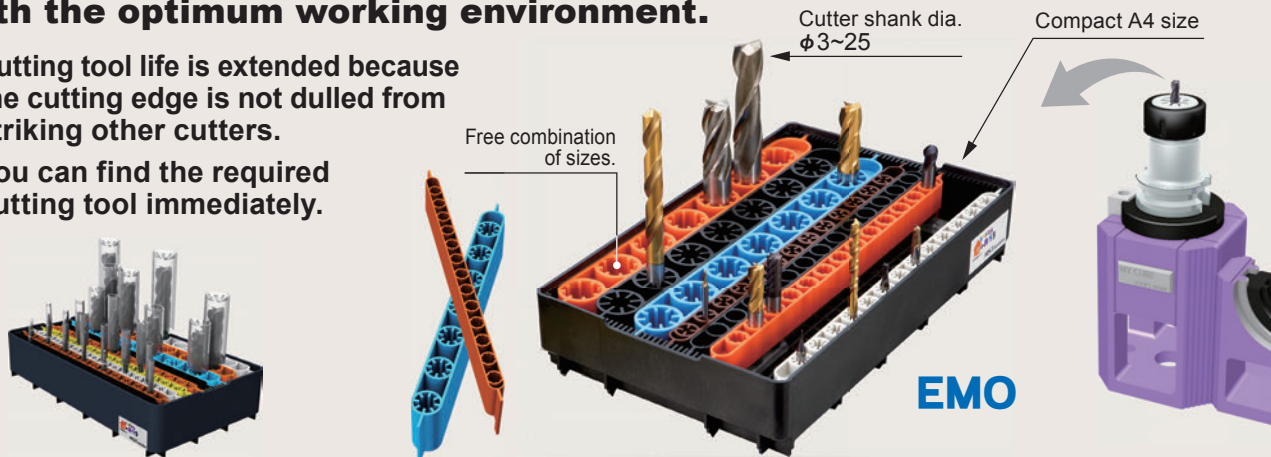

Value set

This is a convenient value set that can be immediately used and handles tool shank diameters of 3 mm to 12 mm. (Stores 156 cutting tools)

CODE	Stand	Base	TOOL CAP	TOOL CAP storage box																																
EMO-SET-01	<table border="1"> <thead> <tr> <th>Cutter dia</th> <th>Q'ty</th> </tr> </thead> <tbody> <tr><td>φ 3</td><td>1</td></tr> <tr><td>φ 4</td><td>2</td></tr> <tr><td>φ 6</td><td>3</td></tr> <tr><td>φ 8</td><td>2</td></tr> <tr><td>φ 10</td><td>2</td></tr> <tr><td>φ 12</td><td>2</td></tr> </tbody> </table>	Cutter dia	Q'ty	φ 3	1	φ 4	2	φ 6	3	φ 8	2	φ 10	2	φ 12	2	<table border="1"> <thead> <tr> <th>Q'ty</th> </tr> </thead> <tbody> <tr><td>1</td></tr> </tbody> </table>	Q'ty	1	<table border="1"> <thead> <tr> <th>Cutter dia</th> <th>Q'ty</th> </tr> </thead> <tbody> <tr><td>φ 3</td><td>50</td></tr> <tr><td>φ 4</td><td>50</td></tr> <tr><td>φ 6</td><td>50</td></tr> <tr><td>φ 8</td><td>50</td></tr> <tr><td>φ 10</td><td>50</td></tr> <tr><td>φ 12</td><td>50</td></tr> </tbody> </table>	Cutter dia	Q'ty	φ 3	50	φ 4	50	φ 6	50	φ 8	50	φ 10	50	φ 12	50	<table border="1"> <thead> <tr> <th>Q'ty</th> </tr> </thead> <tbody> <tr><td>1</td></tr> </tbody> </table>	Q'ty	1
	Cutter dia	Q'ty																																		
φ 3	1																																			
φ 4	2																																			
φ 6	3																																			
φ 8	2																																			
φ 10	2																																			
φ 12	2																																			
Q'ty																																				
1																																				
Cutter dia	Q'ty																																			
φ 3	50																																			
φ 4	50																																			
φ 6	50																																			
φ 8	50																																			
φ 10	50																																			
φ 12	50																																			
Q'ty																																				
1																																				
			<p>φ 3 : 13pcs. φ 4 : 26pcs. φ 6 : 39pcs. φ 8 : 26pcs. φ 10 : 26pcs. φ 12 : 26pcs.</p>																																	

Stand

Parts for storing and securing cutting tools. It is possible to identify the cutting tool size by color, and the cutting tool you need can be found at a glance. Use this stand inserting it into the base.

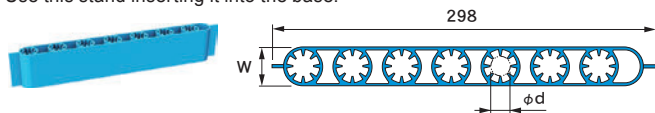

CODE	φd	W	max. Q'ty	Color	Q'ty
EMO-STD 3-2	3	15 mm (1W)	13 pcs./cutting tools/stand	Black	2
-5				Brown	5
-STD 4-2				Brown	2
-5				Gray	5
-STD 6-2				Gray	2
-5	Yellow	5			
-STD 8-2	8	15 mm (1W)	13 pcs./cutting tools/stand	Yellow	2
-5				Orange	5
-STD 10-2				Orange	2
-5				Black	5
-STD 12-2				Black	2
-5	Blue	5			
-STD 16-2	16	30 mm (2W)	7 pcs./cutting tools/stand	Blue	2
-5				Orange	5
-STD 20-2				Orange	2
-5				Gray	5
-STD 25-2				Gray	2
-5	Gray	5			

Base

Container for holding the stands. Stands can be arranged by changing the combination of stands freely.

CODE	Q'ty
EMO-BAS-1	1
-3	3

Note

- 12 rows for the stands of 3mm to 12mm diameter or 6 rows for the stands of 16mm to 25mm diameter.
- The left-right orientation of the stands can be set.

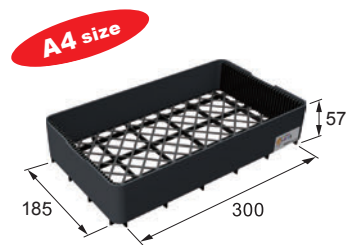

Example of stand arrangement

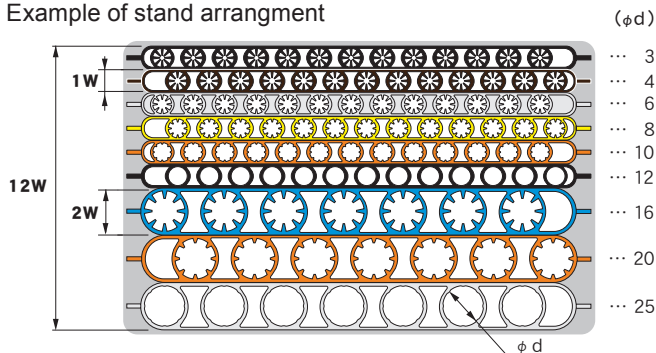

TOOL HOLDER STORING CABINET

Compact Storage Box for anti-rust treatment of tool holders.

Orderly storing with name plate

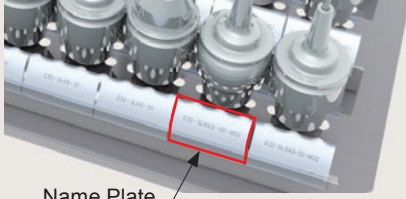

Name Plate

Transparent case!!

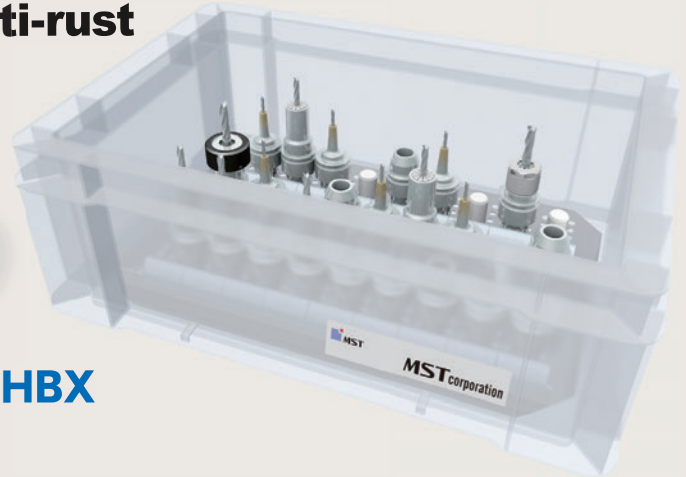

Freely arrangeable

A multi-hole base plate is employed. Supports a variety of holder specifications using pins that can be freely changed and relocated.

HBX

Three types of container boxes.

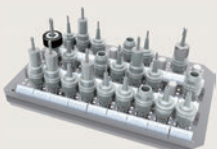

Horizontal type



Vertical type

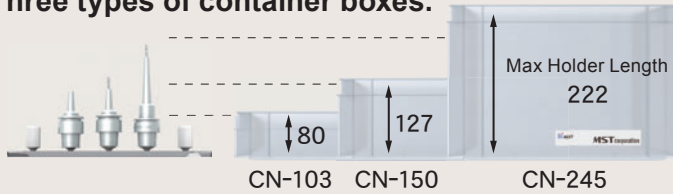

Standard Set

CODE	max. Q' ty	Container box	Pin	Q' ty	Shank type
HBX-A40	24	CN-150	HBX-PNE40	18	HSK-A40
-A50	15	-245	-PNE50	15	-A50
-E25	40	-150	-PNE25	32	-E25
-E32			-PNE32		-E32
-E40	24		-PNE40	18	-E40
-E50	15	-245	-PNE50	15	-E50
-F63	10	-150			-F63
-15T	40		-PN15T	16	15T(BROTHER)
-20T			-PN20T		RS20/20T(SUGINO)

Contents of set

- Base plate ●Container box ●Pin

Option

- Eyenut ●Rail ●Name Plate ●Lid for Container Box

Note

- Knock-down type. A wrench (5mm) is required.

Base plate

A multi-hole base plate is employed. Supports a variety of holder specifications using pins that can be freely changed and relocated.

CODE
HBX-BP01

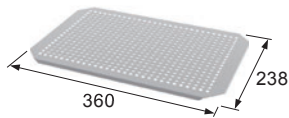

Container box

CODE	H		Shank type
	Outside dimension	Inside dimension	
CN-103	103	88	—
-150	150	135	E25, 32, 40/15T/20T
-245	245	230	A50, E50, F63

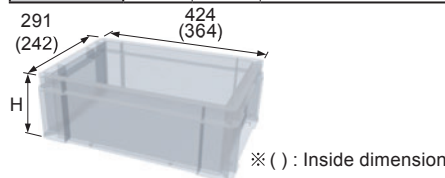

Pin

CODE	Q' ty	Size
HBX-PNE25	10	φ13.5 × H20
-PNE32		φ16.5 × H25
-PNE40	5	φ20.5 × H29
-PNE50		φ25.5 × H36
-PN15T		φ26.5 × H54
-PN20T		φ30.5 × H62

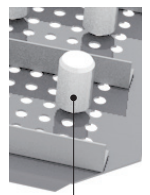

Pin

Std. Access.

- Mounting bolt (M6)

Eyenut

CODE	Q' ty
HBX-ENM6	2

Std. Access.

- Mounting bolt (M6)

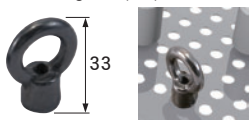

Rail (for name plate)

CODE	Q' ty	L	NOTE
HBX-R210	6	210	Vertical type
-R330	4	330	Horizontal type

Std. Access.

- Mounting bolt (M5)

Required for attaching name plate

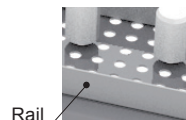

Name plate

CODE	Q' ty
HBX-NP01	40

Attaches easily to the rail.

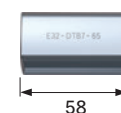

Freely cut to required overall length

Lid for container box

CODE
CN-FT



Feature

Shrink-fit Heater

MONO 3° MONO CURVE

MONO Series

2PIECE type

UNO

HYPER version

STRAIGHT arbor

OTHERS

PERIPHERALS

Technical Information

TOOL SET UP STAND

Tool clamping fixture

The setup time can be shortened. Not only can you mount cutting tools simply and quickly without using other tools, but also clamping collets and retention knobs!

プチボール
Petit Ball 40
BT40 / DIN40 / CAT.40



Freely set vertically or horizontally

Guaranteed accuracy

Uses a special resin that prevents scratches on the taper.



マイキューブ
MY CUBE 50
BT50 / DIN50 / CAT.50

マイキューブ
MY CUBE 100
HSK-A100



Vise clamping type
HF SERIES

BT30 / BT40 / BT50
HSK-A40 / A50 / A63 / A100
E32 / E40 / E50 / F63
T40 / T50 / T63 / T100



Affordable



Petit Ball / MY CUBE

CODE	Shank type	Kg
PETIT BALL 40	BT40 / CAT. 40 / DIN40	6.1
MY CUBE 50	BT50 / CAT. 50 / DIN50	9.7
MY CUBE 100	HSK-A100, T100	9.6

Option

- Adapter (Petit Ball40, MY CUBE 50)

Std. Access.

- Name plate

Caution

- Prepare 2 bolts for installation.
(Petit Ball : M8, MY CUBE : M12)

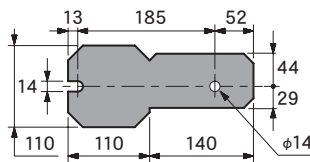
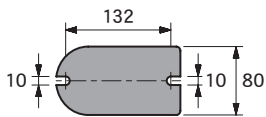
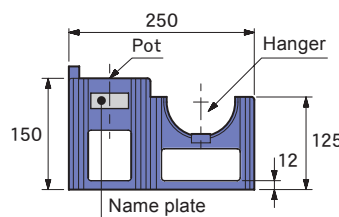
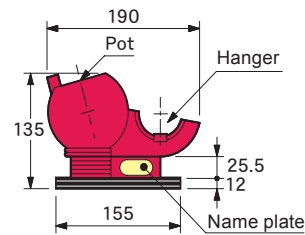

HF series

CODE	Fig.	Shank type	H	W	t	Kg
HF-BT30	1	BT30	77	70	30	0.8
-BT40		BT40	90	90	37	1.2
-BT50		BT50	—	—	—	2.2
HF-A40	1	HSK-A40, T40	72	60	30	0.8
-A50		-A50, T50	77	70	37	1
-A63		-A63, T63	87	90	—	1.2
-A100		-A100, T100	—	—	—	2.1
HF-E32	3	HSK-E32	98	64	—	1
-E40		-E40	100	70	—	1.1
-E50		-E50	106	80	—	1.3
HF-F63	3	HSK-F63	120	90	—	1.6

Adapter

Multi-purpose usage

CODE	Model	Adapter	Shank type	
AP40-T30V	PETIT BALL 40	For pot	BT30	
-T30H		For hanger	BT30	
-S25H			ST25T-DTB7	
-S32H			ST32T-DTB7, 12	
AP50-T30V	MY CUBE 50	For pot	BT30	
-T40V			BT40/CAT.40/DIN40	
-A63V			HSK-A63, T63	
-F63V			HSK-F63	
AP50-T30H		For hanger	BT30	BT30
-T40H			BT40	BT40
-A63H	HSK-A63, T63		HSK-A63, T63	
-F63H	HSK-F63		HSK-F63	
-S25H		ST25T-DTB7	ST25T-DTB7	
-S32H		ST32T-DTB7, 12	ST32T-DTB7, 12	

Adapter for pot



Adapter for hanger

Adapter for pot



Adapter for hanger

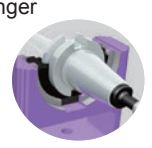

At your request, your company name will be engraved.

Up to 12 characters (upper-case alphabetic characters, numeric characters, and/or hyphens).



Petit Ball



MY CUBE

Fig. 1

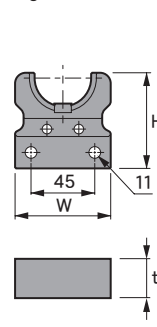

Fig. 2

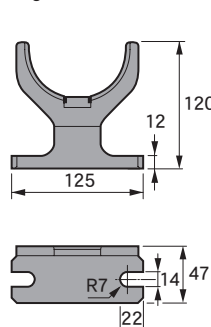
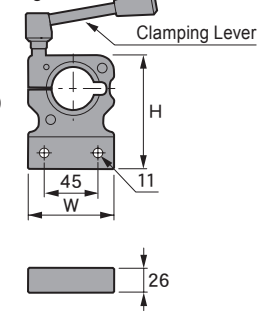

Fig. 3



Achieves high-precision machining by cleaning the machine spindle tapered hole.

Replaceable wiper

Dirt doesn't re-adhere thanks to the use of replaceable wipers. When wipers get dirty, please change their position, and when the entire wiper gets dirty, please replace it. This will allow your operations to always take place under clean conditions. It is very economical compared to disposable cleaners.



Excellent dirt adsorption

We use a spongy resin for the wiper. Micron-size air bubbles catch and hold on to oil and powdery cutting chips.

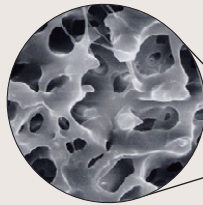

Electron microscope photo



SET CODE	Enabled spindles and holders	Plug code	Grip code
CLT-NT30-G2	BT30 / DIN30 / CAT.30	CLT-NT30	GR25-100
-NT40-G3	BT40 / DIN40 / CAT.40	-NT40	GR35-100
-NT50-G3	BT50 / DIN50 / CAT.50	-NT50	
-A40 -G2	HSK-A40 / T40	CLT-A40	GR25-100
-A50 -G2	-A50 / T50	-A50	
-A63 -G3	-A63 / T63	-A63	GR35-100
-A100-G3	-A100 / T100	-A100	
-E 25 -G1	HSK-E-25	CLT-E25	GR18- 80
-E 32 -G4	-E 32	-	-
-E 40 -G2	-E 40	-E 40	GR25-100
-E 50 -G2	-E 50	-E 50	
-F 63 -G2	HSK-F63	CLT-F63	GR25-100
-F 80 -G3	-F 80	-F 80	GR35-100
CLT-SLK 6-G1	SLK 6	CLT-SLK 6	GR18- 80
-SLK 8-G1	SLK 8	-SLK 8	
-SLK12-G2	SLK12	-SLK12	GR25-100
-C10 -G1	CTH10 / CTA10	CLT-C10	GR18- 80
-C20 -G2	CTH20 / CTA20	-C20	GR25-100
-C25 -G3	CTH25 / CTA25	-C25	GR35-100
-D 7 -G1	DTA 7 / DTB 7 / DTE 7	CLT-D 7	GR18- 80
-D12 -G4	DTA12 / DTB12 / DTE12	-	-

Replacement Wiper

This contains 3 sets.

CODE
CWP-NT30
-NT40
-NT50
-A40
-A50
-A63
-A100
-E 25
-E 32
-E 40
-E 50
-F 63
-F 80

CODE
CWP-SLK 6
-SLK 8
-SLK12
-C10
-C20
-C25
-D 7
-D12

* Plugs and grips can be purchased separately.
* 3 sets of wipers are included with each set.



Plug

For Spindle	For Holder
CLT-NT30 -NT40 -NT50	CLT-SLK 6 -SLK 8 -SLK12
CLT-A40 -A50 -A63 -A100	CLT-C10 -C20 -C25
CLT-E25 -E 40 -F 63 -F 80 -E 50	CLT-D 7

Grip

GR35-100	
GR25-100	
GR18-80	



Feature

Shrink-fit Heater

MONO 3°
MONO CURVE

MONO Series

2PIECE type

UNO

HYPER version

STRAIGHT arbor

OTHERS

PERIPHERALS

Technical Information

TEST BAR CHECKMATE

For machine spindle maintenance

Feature
Shrink-fit Heater
MONO 3° MONO CURVE
MONO Series
2PIECE type
UNO
HYPER version
STRAIGHT arbor
OTHERS
PERIPHERALS
Technical information

The maintaining machine spindle run-out accuracy allows superior machining quality. Maximizes tool holder performance!

- ▷ 20% lighter hollow design makes it easy to use.
- ▷ The actual measurement values are marked on the body.
- ▷ Ideal for setting Z axis datum.
- ▷ Reasonable price.

You can recognize the exact run-out accuracy and the highest run-out of the spindle.

You can check the spindle condition more precisely using the run-out value and position marked on the body.

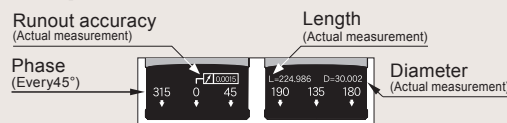

Periodically checking the run-out accuracy will result in superior machining.

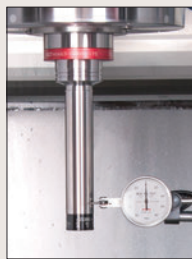

It can be installed into the spindle in every phase.

There is no drive-key groove, so measurements can be made without worrying about the phase.



Handy CMA type

Allows you to check the dynamic accuracy thanks to optional balance adjustment.

The name ring and scale ring protect it from scratches and dents.

The taper area and straight area do not touch the table surface even if they are placed horizontally.

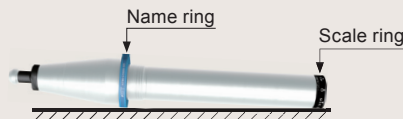

Full-fledged CMB type

Z-axis deflection and spindle travel accuracy can be measured.

	CODE	Fig.	φD	φD1	φD2	L	L1	L2	Kg	
BT/DIN/CAT.	NT30 -CMA20-125	1	20	32	50	125	45	65	0.7	
	NT40 -CMA25-175	2	25	42	63	175	50	110	1.3	
	NT50 -CMA30-225		30	53	80	225	65	145	3.5	
	NT30 -CMB30-175	1	30	32	50	175	45	115	1.0	
	NT40 -CMB40-325	2	40	42	63	325		265	2.8	
	NT50 -CMB50-325		50	53	80		60	250	5.7	
HSK-A / HSK-E	HSK32 -CMA20-125	3	20	26	37	125	35	75	0.4	
	32			50	45		65	0.5		
	HSK40 -CMA20-125		25	42	63	175	50	110	1.0	
	HSK50 -CMA25-175	4	30	53	80	225	65	145	1.2	
	HSK63 -CMA25-175				100				3.0	
	HSK80 -CMA30-225				125				4.1	
	HSK100-CMA30-225									
	HSK125-CMA30-225									
	HSK32 -CMB25-175	3	25	26	37	175	35	125	0.7	
	HSK40 -CMB30-175							40	120	0.9
	HSK50 -CMB40-225							40	42	63
	HSK63 -CMB40-325	4	50	53	80	325	60	250	2.7	
HSK80 -CMB50-325								4.4		
HSK100-CMB50-325								5.2		
HSK125-CMB50-325								6.3		
HSK-F	HSK63F-CMA25-175	4	25	42	63	175	50	110	1.2	
	HSK80F-CMA30-225								30	53
	HSK63F-CMB40-325	4	40	42	63	325	45	265	2.7	
	HSK80F-CMB50-325								50	53

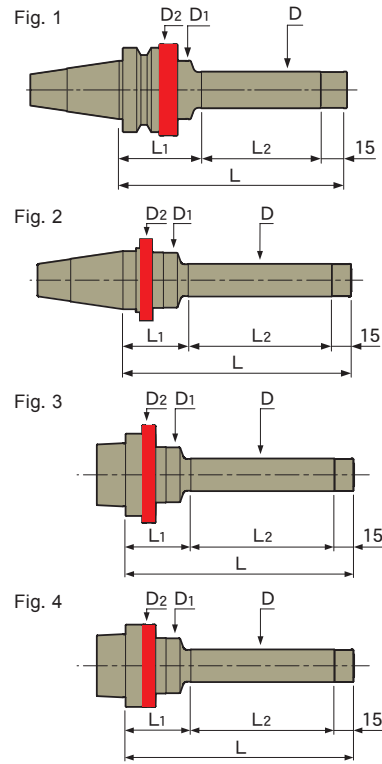

The sub-zero treatment prevents secular change.

Option

- Coolant duct(HSK-A)
- Retention knob(BT)
- Exclusive retention knob(CAT. / DIN)
- Balance adjustment (only for CMA type) less than G2.5 / 30000min⁻¹
- *Please order by adding "BL" to the end of the code. (Ex. : HSK63-CMA25-175 BL)

Note

- NT type is available for BT/CAT. and DIN spindle by changing the retention knob.
- HSK type is available for both HSK-A and HSK-E spindles.
- HSK-F type is available only for HSK-F spindle.
- A special design retention knob is required for CAT./DIN spindle.
- A market standard retention knob for ANSI/DIN/ISO is not available. Contact us for detail.
- Use a market standard retention knob for the BT spindle.
- NT30 type can be installed into a spindle at 0° and 180°.

Exclusive retention knob

CODE	Shank
P-576	CAT. 40
-575	CAT. 50
-578	DIN40
-577	DIN50

Std. Access.

- Accuracy inspection sheet

Caution

- A.T.C is not available. (except for NT30)



Goo CHECKER ZPM type

Set up the original point on the Z axis / measuring tool for reference position

**Shareable Z-axis origin for multiple machining centers.
Easy work-piece origin setting.
Precise work-piece flatness and step measurement possible!**

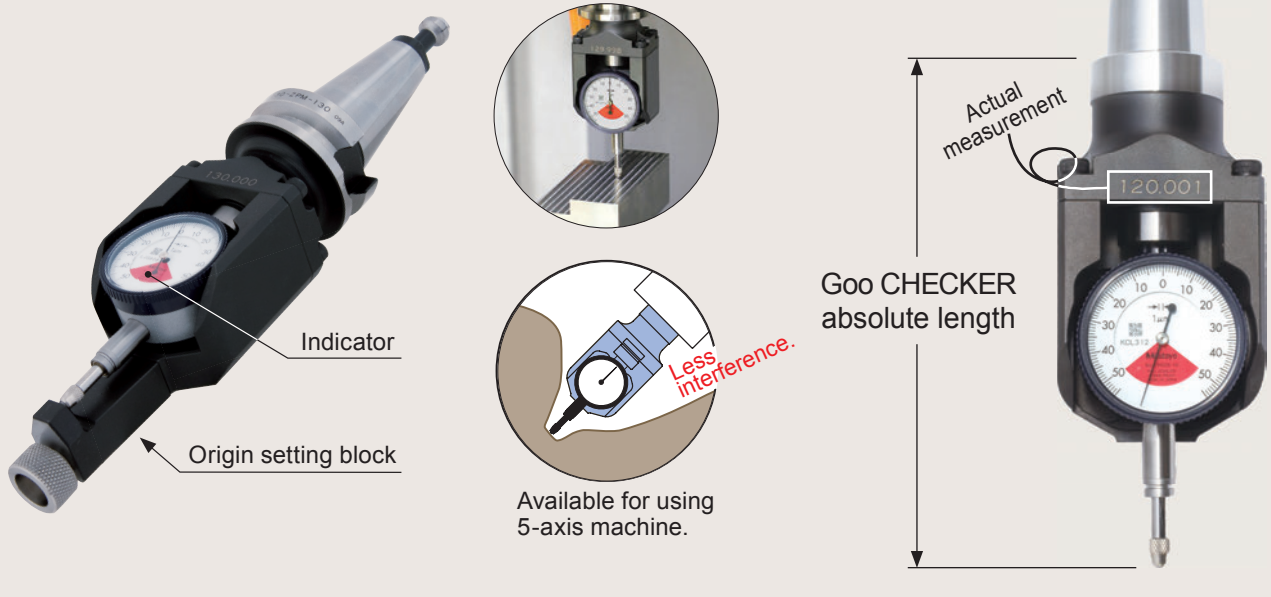

Easy Z-axis origin setting

Easy measurement for Z-axis origin to work-piece datum surface.

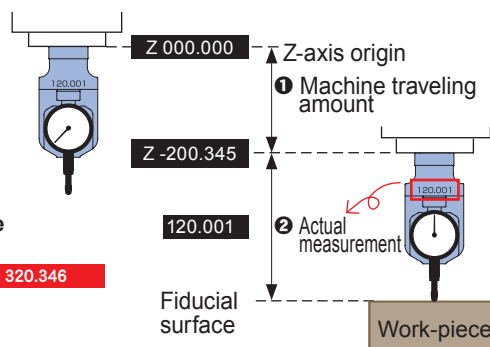

(Ex.)
Distance from Z-axis origin to work-piece datum surface.

$$200.345 + 120.001 = 320.346$$

- ① Machine traveling amount
- ② Goo checker absolute length

Shareable Z-axis origin for several machining centers

After measuring the distance from the Z-axis origin to the table surface of each machining center and correcting any variations, multiple machining centers can share the tool holders and programming.

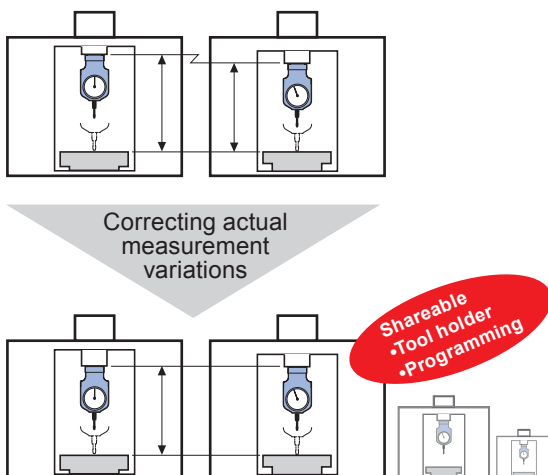

Flatness check

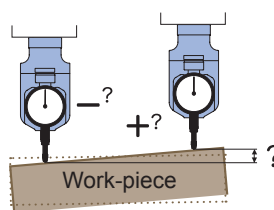

Step measurement

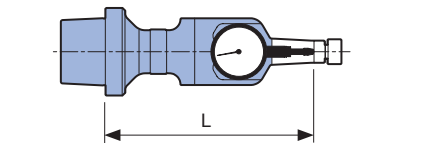
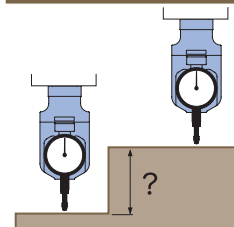

CODE	L	Kg
BT30 -ZPM-130	130	1
-165	165	1.2
BT40 -ZPM-150	150	1.3
-210	210	1.5
BT50 -ZPM-180	180	2.9
-240	240	4.1
A63 -ZPM-150	150	1.2
-210	210	1.5
A100 -ZPM-180	180	2.5
-240	240	3.8
E32 -ZPM-120	120	0.7
-165	165	1
E40 -ZPM-120	120	0.8
-180	180	1.1
E50 -ZPM-150	150	1
-195	195	1.3
F63 -ZPM-150	150	1.1
-210	210	1.3
F80PD-ZPM-180	150	1.1
-240	210	1.3
DN40 -ZPM-150	150	1.3
DN50 -ZPM-180	180	2.9
CT40 -ZPM-150	150	1.3
CT50 -ZPM-240	240	4.1

- Option
 - Retention knob(BT/ CAT./ DIN) → P.216
- Std. Access.
 - Master block ● Indicator, 1/1000 reading
- Caution
 - A.T.C is not available. (except for BT30)

Feature
Shrink-fit Heater
MONO 3° MONO CURVE
MONO Series
2PIECE type
UNO
HYPER version
STRAIGHT arbor
OTHERS
PERIPHERALS
Technical Information

Watch the video and you'll be ready to carry out maintenance immediately!



Removing dents and scratches restores the high accuracy.

Comes with tools

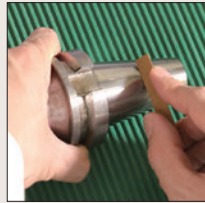

Tool holder



Fixture

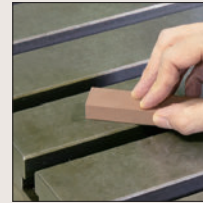

Machine table



Work-piece

Contents

1. The negative influence of dents, scratches and rust.
2. Practical ways to remove dents, scratches and rust - Tool holder edition.
3. Practical ways to remove dents, scratches and rust - Machine table, Fixture edition.
4. Introduction of tools.

PR Movie



Basic Kit

CODE

MTN-BSK1



MTN-MV1



Contents of kit

Tools	Specification	Q'ty
Maintenance DVD	DVD	1
Oilstone-Both ends tapered type	#500	2
-Triangular type		2
-Square type		1
-White type	#3000	1
Rubber grinding stone-Square type	#320	1
Diamond file-Flat type	#120	1
-Round type		1
-Triangular type		1
Wire brush	Hardened steel wire	1
Water-resistant Sandpaper	#1000	10
Cotton-tipped stick-Long type	-	10
-Short type		10
Scraper for clearance gap		1
Light	AA battery×2	1
Mat for work	Rubber mat	2
Kit case	-	1

Note

- Can be sold individually.

Replacement tool set

CODE

MTN-RSS1

Option

- Oilstone-Both ends tapered type(2pcs.)
- Oilstone-Triangular type(2pcs.)
- Water-resistant Sandpaper (10sheets)
- Cotton-tipped stick-Long type (10pcs.)
- Cotton-tipped stick-Short type (10pcs.)



Oilstone-Both ends tapered type



Oilstone-Triangular type



Water-resistant Sandpaper



Cotton-tipped stick-Long type



Cotton-tipped stick-Short type

Single unit

CODE	Q'ty
MTN-MV1	1
MTN-OS1	1
-OS2	1
-OS3	1
-OS4	1
-RS1	1
-DY1	1
-DY2	1
-DY3	1
-WB1	2
-WP1	20
-MB1	100
-MB2	100
-SS1	1
-HL1	1
-MS1	2
-KC1	1

MTN-OS1

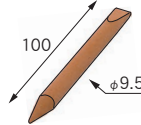

-OS2

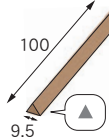

-OS3

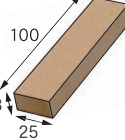

-OS4

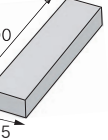

MTN-RS1

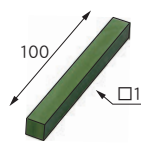

-DY1

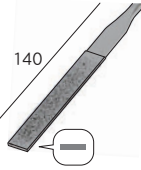

-DY2

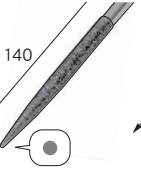

-DY3



MTN-WB1



-WP1

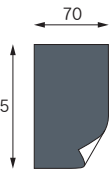

-MB1



-MB2



MTN-SS1

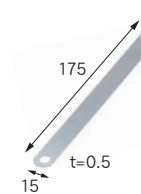

-HL1



-MS1

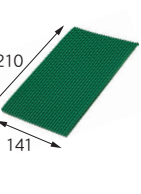

-KC1



Anti-rust oil set

CODE

MTN-ARS1

Contents

- Anti-rust oil
- Anti-rust oil (Refill)

Note

- Can be sold individually.



Anti-rust oil

CODE
MTN-AR1



Anti-rust oil (Refill)

CODE
MTN-AR2